

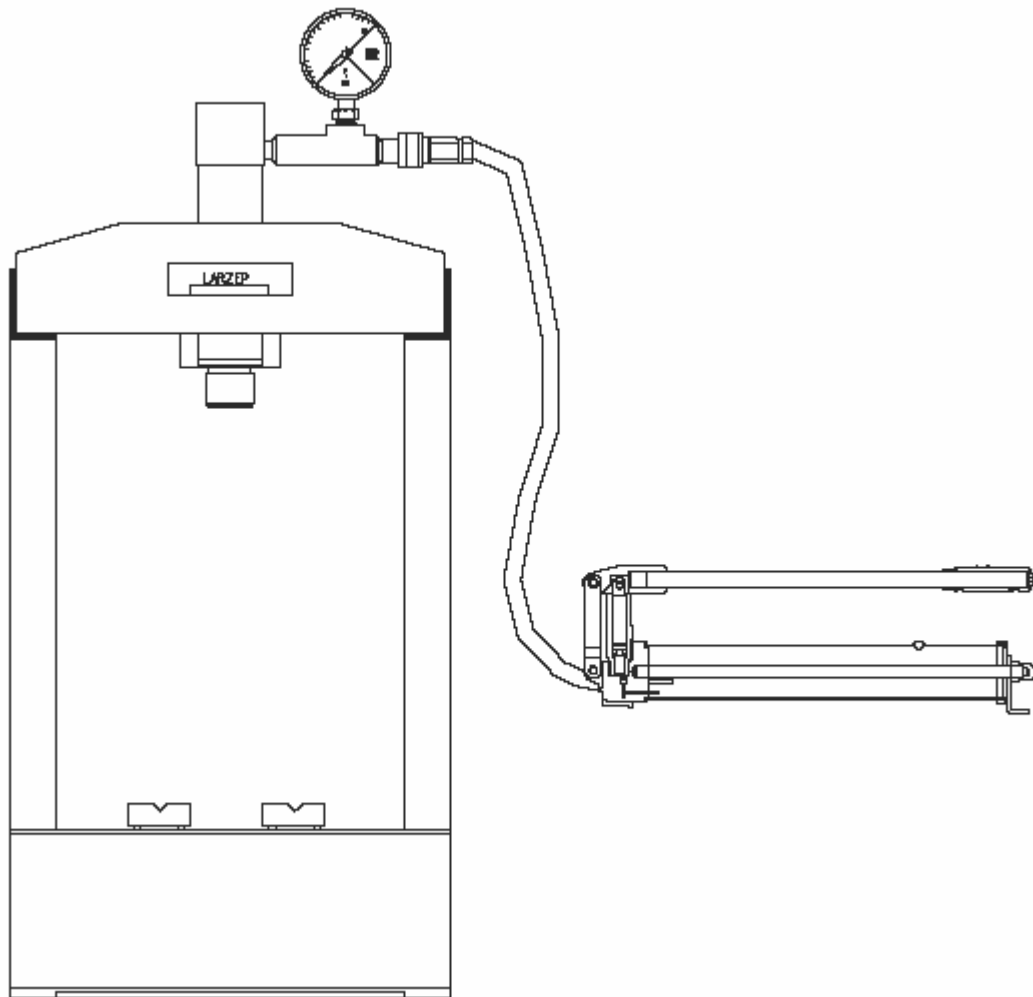

BENCH HANDPUMP PRESS 20 ton “ECM02013”



LARZEP, S.A.
Avda. Urutiaga, 6. 48269 MALLABIA (Vizcaya).Spain
P. O. Box, 27. 20600 Eibar (Guipúzcoa). Spain
Tel. (+34) 943-171200 - Fax. (+34) 943-174166
E-mail: comercial@larzep.com
www.larzep.com

LARZEP HYDRAULIC (UK) LTD
UNIT 1A PARK ROAD INDUSTRIAL ESTATE
CONSETT CO. DURHAM DH85PY. ENGLAND
Tel. (+44) - 1207-582266 - Fax. (+44)- 1207-583366
E-mail: enquire@larzep.co.uk
www.larzep.co.uk

INDEX

1. BEFORE USING THE EQUIPMENT 2
2. TECHNICAL FEATURES 2
3. ESSENTIAL SAFETY REQUIREMENTS 3
4. TRANSPORT AND INSTALLATION 3
5. MAINTENANCE..... 4
6. WARRANTY..... 4
7. DECLARATION OF CONFORMITY 5

ANNEX

❖ GENERAL DRAWING

1. BEFORE USING THE EQUIPMENT.

Upon removing the protective packaging from the crane, carefully inspect it. Check for:

- 1- Oil leaks, signs of corrosion.
- 2- Damage to the hydraulic cylinder and hydraulic line.
- 3- Cracks or dents on the frame and the hydraulic cylinder's attachments to the frame.
- 4- Loose or damaged screws or joints.
- 5- Damaged or incorrectly assembled accessories.

If you find any damage or fault with the product, clearly label it and place it in a location where it will not be available for use until an authorized service dealer has repaired the fault.



Never use hydraulic equipment that is damaged or suspected to be in poor condition.

Familiarize yourself and your co-workers with the equipment. Before you begin using the jack, carefully read and observe all instructions and recommendations enclosed in the packaging. Your negligence in this matter may cause personal injury or material damage.



Do not loose the instruction manual.

Before using the equipment for the first time, purge any air from the hydraulic circuit by opening the pump's relief valve, placing the pump with its head down, and pumping several times.

Do not operate hydraulic equipment near open flame, explosives, and sources of intense heat or any other hazard, which could cause a fire or the damage equipment. The hydraulic equipment should not be exposed to temperatures greater than 60°C when in use or when stored.



If purchasing just a cylinder or pump for use in a press, ensure that you are using the proper combination of pump, cylinder and press frame before assembling the unit. We recommend you seek professional advice on the matter.

When choosing a place for the press, ensure that it will be located over firm, level ground such that the entire base of the press contacts the ground. If any doubt exists as to whether the ground will be able to support the press and the additional weight it will see when in use, distribute the weight over a larger area by placing rigid steel beams or planks under the base of the press.

Store the press with the cylinder's piston fully retracted. We recommend you wrap the cylinder in a protective plastic or place it in a location free of dirt, dust, steel shavings and other foreign matter, which can enter into the cylinder and damage its components.

2. TECHNICAL FEATURES.

HYDRAULIC CYLINDER

MODEL	ECM02013
• Max. Pushing Capacity (ton)	20 ton
• Max. Working Pressure (Kg/cm ²)	700 Kg/cm ²
• Hydraulic Stroke (mm)	130 mm.
• Oil capacity (cc)	431, 37 cc
• Free advance speed (mm/sg)	0, 7 mm/sg
• Max. pressure advance speed	0, 7 mm/sg
• Cylinder ref	KC02013

HAND PUMP

MODEL	W06007
• Tank Capacity (cc)	660 cc.
• Working Pressure (Kg/cm ²)	700 Kg/cm ²

WELDED-MECHANIZED FRAME

MODEL	ECM02013
• Working height (mm.)	330 mm.
• Working width (mm.)	500 mm.
• Total weight (Kg.)	87 Kg.

3. ESSENTIAL SAFETY REQUIREMENTS.

DANGEROUS AREA



Due to the *FUNCTIONAL REASONS* it is considered to be the space between the columns, the bed and the hydraulic cylinder piston.

Due to the *MATERIAL PRESSED* it is supposed to be surrounding area to the machine in case of metal parts being ejected during pressing.

The speed of the hydraulic cylinder during its extension is less than 30 mm/second. Therefore then machine should be considered by the application of ANNEX V of the Declaration of CE Conformity.

Operators standing in the dangerous area around the machine should protect their feet, faces and hands from metal pieces being ejected during pressing.



Feet protection



Face protection



Hands protection

Used materials and components are not for the health and safety of operators. The hand pump contains LARZEP hydraulic oil ISO:HV46.



HIDRAULIC OIL IS TOXIC IF IT ENTERS THE BLOODS STREAM. NEVER PLACE A FINGER OVER ANY ORIFICE OR LEAK, WHICH COULD BE PRESSURIZED, SUCH AS THE HYDRAULIC LINE, AS THIS COULD CAUSE OIL TO BE INJECTED INTO BLOOD STREAM.

- ❖ The pump lever performs the advance of the cylinder.
- ❖ The pump includes an operating screw to relief the cylinder pressure that allows the oil return to the pump.
- ❖ For the equipment working the connection of the pump to the cylinder is necessary.
- ❖ In order to stop the advance pushing of the cylinder, we must stop operating the pump pedal. For a new start-up it is necessary to operate the pump pedal.
- ❖ The construction of machine has been calculated to bear without any breaking under conditions of foreseen utilization and for the whole life of the machine. The hydraulic components have been designed and calculated in compliance with the ANSI B30.1, and have been proved to 875Kg/cm² of pressing.
- ❖ The frame of the machine does not cause to be dangerous in that sense.
- ❖ The hydraulic pump is equipped with an internal security valve in the tank, out of operator's control and rated at 700 Kg/ cm². The hydraulic cylinder is also furnished with a pressure relief valve, rated at 700 Kg/ cm², which prevents the retraction chamber of the cylinder from overpressures in case of obstruction of the return way.
- ❖ All the maintenance operations must be performed while the machine is stopped, thus avoiding this way any potentially dangerous situation. A poor maintenance program of the press does not increase the risk, but obviously will revert in a lower performance.
- ❖ The hydraulic pump is mounted out of the frame and access is very easy. To disassemble the pump unscrews the bolts in the tap cover. In order to disassemble the cylinder it is required first to disassemble the hose and the cylinder from the frame.

ISOLATION OF THE POWER SUPPLY

- ❖ Release the rapid coupling from the pump.
- ❖ The machine is designed to assure that the operator performs all maintenance tasks in an easy and safe way. All the components that would require any maintenance operation are easy accessible.

The press, the cylinder and the pump have their corresponding serial numbers marked on them. In addition to it, you can find a sticker label showing the commercial reference, capacity, working pressure, name and address of the manufacturer.

4. TRANSPORT AND ERECTION.

The machine is delivered properly packed in a wooden ballet. For it's handling, it is recommended to use a forklift truck or a crane. In the last case, it is necessary to make the slings trespass the arc of the frame. When doing this operation, you should be cautious and prevent the flexible hoses and couplings from any damage.



The machine is stable enough to operate without fixing, but if is placed in an area commonly operated by mobile machinery (cranes, lifting equipment...) it is strongly recommended to fix it to the desired place by drilling the supporting plates.

HYDRAULIC CONNECTION

Unscrew the rapid coupler site in the cylinder, and connect the hose, screwing the rapid coupler to the limit with the hand.

INSTALLING THE GAUGE

- 1-Replace the threaded tap in the top of the cylinder by the gauge. (Supplied separately)
- 2-Tighten the gauge cone to the gauge adaptor seat by using a flan wrench size 22.
- 3-Hold the gauge screen by hand during threading process and after reaching a comfortable reading position set the gauge screen free so that it turns the last quarter solidarily with the thread.

CHECKING THE RIGHT OPERATION OF ALL DEVICES AND MECHANISM

1. Select the working maximum pressure. In manual presses 700 Kg/cm².
2. With the hand in the lever, pump several times.
3. Check the cylinder advance.
4. Check that the cylinder piston return by internal spring. In both cases, to maintain the movement is necessary act over the lever.
5. Without any material in the press, repeat the advance movement, pumping until reach the cylinder full stroke. In that moment the pressure will start to be increased and we can observe it now in the gauge. This pressure will go on increasing until reach the installation maximum pressure, previously chosen. In this stage, the cylinder maintains the reached pressure, (the gauge maintains the reading). Check there are no leaks in the installation (gauge intake, couple, etc.)
6. To return the cylinder and eliminate the installation pressure, open the washer turning it to the left. The return may be slower at the end of the backstroke.
7. Put the material to be treated in the press.

MAXIMUM WORKING PRESSURE

The maximum pressure developed by the hydraulic system is 700 Kg/cm². An internal security valve discharges when the system reaches that pressure.

5. MAINTENANCE.

The hydraulic circuit of the press is closed, so in normal conditions no oil leakage should be coming up. In case of oil leakage, after the proper repairing work, you should fill up the tank with hydraulic oil by LARZEP (Ref. AZ8901); the pump is equipped with an oil level indicator to control the need quantity of oil. As far as a non-continuous use of the press is concerned (1 hour per day), oil replacement should be done once a year.



To empty the tank, you should remove the cover and take the oil out to another container. Please, bear in mind the existing rules for waste processing when handling the used oil. Keep greasy and lubricated the pin bearings, the piston and in general all the parts that might be in friction.

FREQUENT INSPECTION: a visual inspection carried out before and after each operation.

PERIODIC INSPECTION: a thorough examination of the equipment, both externally and internally. The equipment is labelled with the inspection date and the data is logged in a register.

In a **FREQUENT INSPECTION**, check for:

- Piston wear, signs of corrosion
- Wear or damage in the cylinder, frame, accessories, work table, supports or pump.
- Oil leaks
- Loose or damage screws or joints

In a **PERIODIC INSPECTION**, check for the same problems as in a frequent inspection but in addition, the hydraulic equipment should be disassembled and cleaned by an authorized service dealer so that it may be examined internally.

Periodically clean and lubricate the press's moving parts, such as the piston, winch, pumping mechanism, etc. This is especially important when working in salty or humid environments.

Hydraulics equipment, which is subject to the very severe environmental conditions mentioned, previously should be cleaned and lubricated after each use.

To clean the hydraulic equipment, begin by removing the pump's oil reservoir plug and draining all the oil. Fill reservoir with degreasing liquid and thoroughly circulate it through the hydraulic equipment. After completely purging the liquid out of the hydraulic circuit, align the pump vertically with the head down and fill the reservoir with the new hydraulic oil until the oil level rises to the orifice

USE ONLY LARZEP HYDRAULIC OIL

Other grades of oils or types of hydraulic fluid (such as brake fluid) may affect the performance of the equipment or cause the deterioration of the seals.



DO NO ATTEMPT TO FILL THE PUMP WITH OIL WHILE IT IS CONNECTED TO A CYLINDER WHICH IS SUSTAINING A LOAD BECAUSE IT MAY OVERPRESSURIZE THE RESERVOIR WHEN THE PISTON RETRACTS AND CAUSE DAMAGE OR INJURY

Always use the original LARZEP parts to prolong the service life of your hydraulic equipment. **LARZEP S.A.** or your authorized dealer can supply you with original parts for simple maintenance work.

PROBLEMS	CAUSES	SOLUTIONS
1. The piston does not advance.	- The pump's relief valve is open.	1. Close the relief valve.
	- Air in the hydraulic circuit.	2. Open the pump's relief valve, and purge the hydraulic circuit.
	- No oil in the reservoir.	3. Fill the oil reservoir until the oil level reaches the plug's orifice.
	- Dirt in the hydraulic circuit.	4. Clean the hydraulic circuit.
	- Worn or damaged check valve.	5. Take the press to an authorized service dealer.
	- Improperly connected hydraulic line	6. Ensure that the hydraulic line is properly connected.
	- Deformed piston.	See Solution 5.
3. The piston will not fully extend.	- Low oil level.	See Solution 3.
	- Deformed piston.	See Solution 5.
4. The piston advances very slowly.	- Air in the hydraulic circuit.	See Solution 2.
	- Dirt in the hydraulic circuit.	See Solution 4.
	- Worn or damaged check valve.	See Solution 5.
	- Improperly connected hydraulic line	See Solution 6.
5. The cylinder slowly loses pressure	- Air in the hydraulic circuit.	See Solution 2.
	- Dirt in the hydraulic circuit.	See Solution 4.
	- Worn or damaged check valve.	See Solution 5.
	-Worn or damaged O-rings	See Solution 5.
6. Oil leak.	- Worn or damaged O-rings	See Solution 5.
	- Improperly connected hydraulic line	See Solution 5.
7. Piston does not fully retract.	- Excessive oil in the reservoir.	7. Ensure that the oil level reaches the plug's orifice.
	- Deformed piston	See Solution 5.
	- Worn or damaged check valve.	See Solution 5.
	- Dirt in the hydraulic circuit.	See Solution 4.
	- Damaged return spring.	See Solution 5.
	- Relief valve closed.	8. Open the relief valve
	- Damaged return spring.	See Solution 5.

6. WARRANTY.

LARZEP, S.A. guarantees its products against all design and manufacturing defects for the durations of two years from the date of purchase. This guarantee does not include the ordinary wear of both metal and non-metal parts, abuse, using the equipment beyond its rated capacity and any wear or damage incurred as a result of using a hydraulic fluid which is not recommended by **LARZEP, S.A.**

Please note that if the equipment is disassembled or serviced by anyone other than an authorized service dealer or by **LARZEP, S.A.**, this guarantee is rendered null and void.

In the event of a warranty claim, return the equipment, to **LARZEP, S.A.** or the authorized dealer which sold you the hydraulic equipment, **LARZEP, S.A.** will repair or replace the faulty equipment, whichever is deemed most appropriate. **LARZEP, S.A.** shall not be held liable for any consequential damages or losses, which may occur as a result of faulty equipment

7. DECLARATION OF CONFORMITY.**DECLARACION DE CONFORMIDAD**

LARZEP, S.A.
Dirección: Avda. Urtiaga, 6
48269 Mallabia ESPAÑA

Declaramos bajo nuestra exclusiva responsabilidad la conformidad de los productos a los que refiere esta declaración, con las disposiciones de la directiva:
89/392/CEE, 91/368/CEE, 93/44/CEE, 93/68/CEE, 98/37/CEE

E**DECLARATION OF CONFORMITE**

Nous, LARZEP, S.A.
Adresse: Avda. Urtiaga, 6
48269 Mallabia SPAIN

Déclarons sous notre seule responsabilité que les produits auxquels se réfère cette déclaration sont conformes aux dispositions des Directives:
89/392/EEC, 91/368/EEC, 93/44/EEC, 93/68/EEC, 98/37/EEC

F**DECLARAÇÃO DE CONFORMIDADE**

Nós, LARZEP, S.A.
Endereço: Avda. Urtiaga, 6
48269 Mallabia SPAIN

Declaramos, sob nossa única responsabilidade, que os seguintes produtos, incluídos nesta declaração estão em conformidade com o disposto na Directiva:
89/392/EEC, 91/368/EEC, 93/44/EEC, 93/68/EEC, 98/37/EEC

P**ÖVERENSSTEMMELSEERKLÆRING**

Vi, LARZEP, S.A.
Adresse: Avda. Urtiaga, 6
48269 Mallabia SPAIN

Erklærer på eget ansvar, at følgende produkter som er omfattet af denne erklæringen, er i overensstemmelse med bestemmelsene i Direktiv:
89/392/EEC, 91/368/EEC, 93/44/EEC, 93/68/EEC, 98/37/EEC

DK**ERKLÆRINGOM OVERENSSTEMMELSE**

Vi, LARZEP, S.A.
Adresse: Avda. Urtiaga, 6
48269 Mallabia SPAIN

Erklærer på eget ansvar, at følgende produkter som dekkes af denne erklæringen, er i overensstemmelse med bestemmelsene i Direktiv:
89/392/EEC, 91/368/EEC, 93/44/EEC, 93/68/EEC, 98/37/EEC

N**ÜBEREINSTIMMUNGSERKLÄRUNG**

Wir, LARZEP, S.A.
Anschrift: Avda. Urtiaga, 6
48269 Mallabia SPAIN

Erklären auf eigene Verantwortung, daß folgende Produkte, auf die sich diese Erklärung bezieht, mit den Bedingungen der Direktiven 89/392/EEC, 91/368/EEC, 93/44/EEC, 93/68/EEC, 98/37/EEC übereinstimmen.

D

Tipo, Type, Typ, Tyypki.

SM / SH / SP / SMP / SX / SMX / ST / STX / SL / SMA / SHA / SSR / T / TE / TD / D / DH /
DDR / Z / ZR / W / X / YA / YG / YZ / HM / HE / HG / HZ / HS / WI / CK / CC / CN / FU / FV
/ FZ / FA / CY / AA / AU / CT / C / KC

A / AB / AC / BL / B / AF / F / HN / DLG / DL / DP / VA / VB / VC / VZ / EC / EE / EG / EM /
EZ / CA / CS

Mallabia, ESPAÑA 2005 / 04 / 27

Lugar y fecha, place and date, lieu et date, plats och datum, paikka ja päivämäärä, udstedelsessted og dato, ort und datum, plaats en datum, local e data, luogo e data.

DECLARATION OF CONFORMITY

We, LARZEP, S.A.
Address: Avda. Urtiaga, 6
48269 Mallabia SPAIN

Declare under our sole responsibility that the following products to which this declaration relates conform with the provisions of Directives:
89/392/EEC, 91/368/EEC, 93/44/EEC, 93/68/EEC, 98/37/EEC

GB**DICHIARAZIONE DI CONFORMITÀ**

Noi, LARZEP, S.A.
Indirizzo: Avda. Urtiaga, 6
48269 Mallabia SPAIN

Dichiariamo sotto la nostra esclusiva responsabilità che i prodotti ai quali questa dichiarazione si riferisce sono conformi quanto previsto dalle Direttive:
89/392/EEC, 91/368/EEC, 93/44/EEC, 93/68/EEC, 98/37/EEC

I**VAATIMUSTEMUKAISUUSVAKUUTUS.**

Me, LARZEP, S.A.
Osoite: Avda. Urtiaga, 6
48269 Mallabia SPAIN

Vakuutamme yksinomaan omalla vastuullamme, että seuraavat tuotteet, joihin tämä vakuutus liittyy, ovat seuraavien Direktiivien vaatimusten mukaisia:
89/392/EEC, 91/368/EEC, 93/44/EEC, 93/68/EEC, 98/37/EEC

FIN**VERKLARINGVAN OVEREENKOMST.**

Wij, LARZEP, S.A.
Adres: Avda. Urtiaga, 6
48269 Mallabia SPAIN

Verklaren geheel onder eigen verantwoordelijkheid dat de volgende producten, waarop deze verklaring heeft in overeenstemming zijn met de bepalingen van Richtlijn:
89/392/EEC, 91/368/EEC, 93/44/EEC, 93/68/EEC, 98/37/EEC

NL**FÖRSÄKRAN OM ÖVERESSTÄMMELSE**

Vi, LARZEP, S.A.
Adress: Avda. Urtiaga, 6
48269 Mallabia SPAIN

Försäkrar under eget ansvar att följande produkter som omfattas av denna försäkran är i överensstämmelse med villkoren i Direktiv:
89/392/EEC, 91/368/EEC, 93/44/EEC, 93/68/EEC, 98/37/EEC

S

LARZEP, S.A.

Nombre y firma, name and signature, nom et signature, namn och underskrift, nimi ja nimikirjoitus, navn og underskrift, name und unterskrift, naam en handtekening, nome e assinatura, nome e firma.

GENERAL DRAWING N° 1

PRENSA HIDRAULICA DE SOBREMESA

Ref.Comercial:ECM02013

DATOS DE LA PRENSA:

CAPACIDAD 20 Tm
LUZ ENTRE COLUMNAS 500 mm
ALTURA MINIMA TRABAJO 220 mm
ALTURA MAXIMA TRABAJO 350 mm

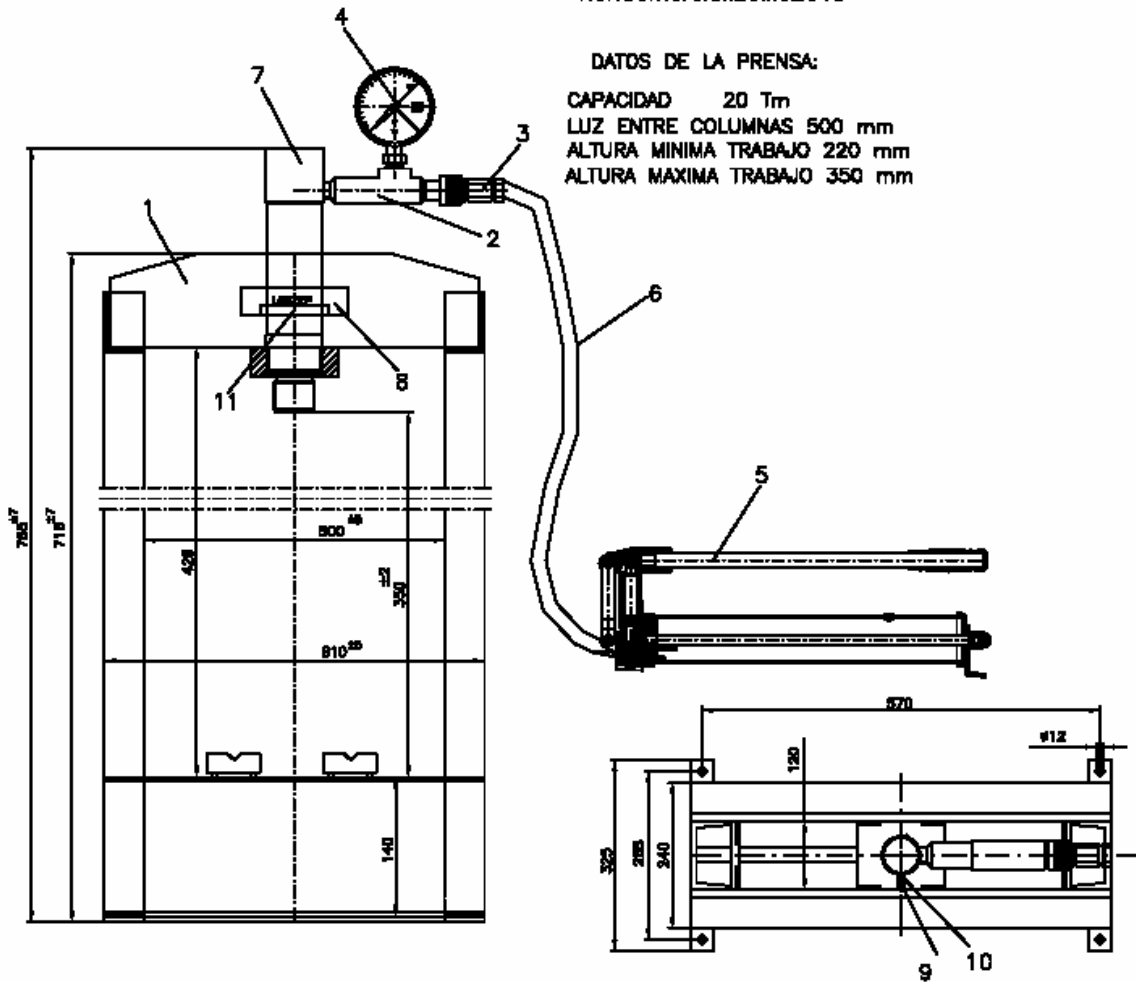

N	DENOMINACION	CODIGO	N Piezas
1	ESTRUCTURA	25A0012	1
2	RACOR ACOPLA.MANOMETRO	AZ1501	1
3	ENCHUFE RAPIDO MACHO	AZ3220	1
4	MANOMETRO	AT01610	1
5	BOMBA	W00607	1
6	MANGUERA	AP2015	1
7	CILINDRO	KC02013	1
8	ETIQUETA	30A0021	1
9	ESPARRAGO	14F0014	1
10	PROTECTOR ROSCA	15L0018	1
11	ETIQUETA (SIN DEFINIR)	30A0080	1

GENERAL DRAWING N° 2

BOMBA HIDRAULICA MANUAL SIMPLE EFECTO

Ref. Comercial: W00607
CAPACIDAD 660 Cm³
PRESION 700 Kg/Cm²

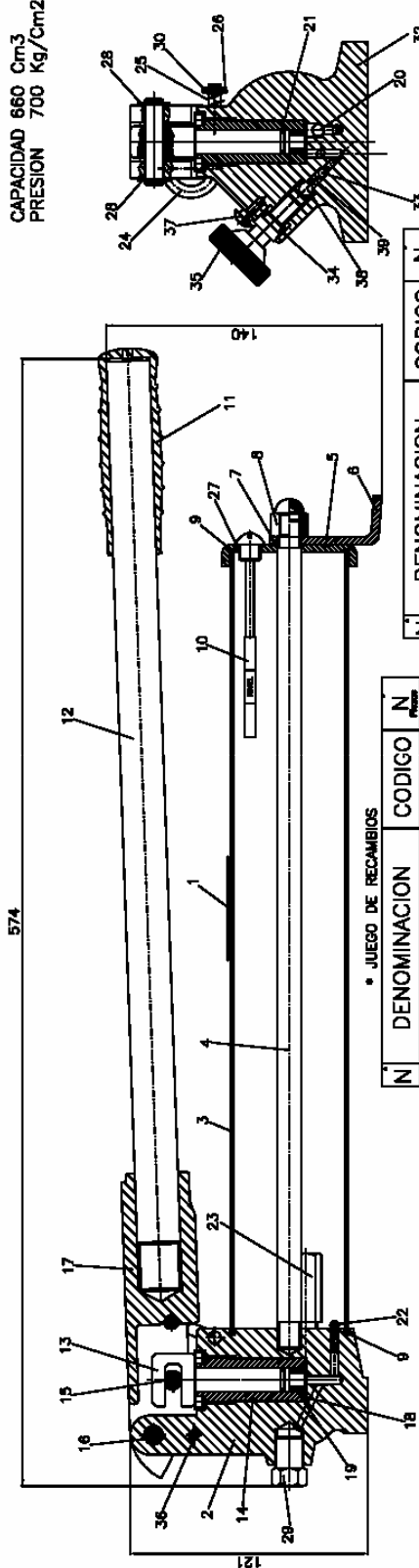

* JUEGO DE RECAMBIOS

N°	DENOMINACION	CODIGO	N°
1	ETIQUETA ADHESIVA	30A0023	1
2	SUBCONJUNTO BASE	50K0036	1
3	DEPOSITO	51B0042	1
4	EJE DEPOSITO	15K0003	1
5	TAPA DE DEPOSITO	32A0013	1
6	PATA DE DEPOSITO	24L0015	1
7	TORICA ANB	12A0048	1
8	TUERCA CIEGA	14B0004	1
9	ANILLO CIERRE	57F0016	2
10	CONJUNTAPON NIVEL	15L0116	1
11	EMPUNADURA	24C0006	1
12	PALANCA	24A0007	1
13	PISTON	54C0004	1
14	CAMISA	15D0023	1
15	EJE	15K0007	1
16	EJE	15K0008	1
17	PORTAPALANCA	24B0026	1
18	ARANDELA JUNTA	57B0011	1
19	TAZA DE PISTON	12A0004	1
20	ESFERA #6	31A0001	1
21	TORICA AN7	12A0005	1
22	FILTRO	13F0001	1
23	VALVULA TARADA A 750 Kg/cm ²	17C0006	1
24	EJE DE TRANSPORTE	15I0156	1
25	MUELLE	13D0003	1
26	ARANDELA DE RETENCION	14D0042	1

N°	DENOMINACION	CODIGO	N°
32	BASE	50K0032	1
33	ESFERA #4	31A0002	1
34	TORICA ANB	12A0047	1
35	TORNILLO DE ACCIONAMIENTO	15H0008	1
36	PASADOR	14E0002	1
37	TORNILLO TOPE	15L0022	1
38	ESFERA #6	31A0001	1
39	MUELLE DE RETORNO	13D0136	1

N°	DENOMINACION	CODIGO	N°
27	TORICA	12A0051	1
28	ARANDELA DE SEGURIDAD	14D0001	2
29	TAPON	15L0003	1
30	ARANDELA PARA M6	14C0004	1
31	ESTUCHE DE CARTON	21D0018	1

TORNILLO DE ACCIONAMIENTO

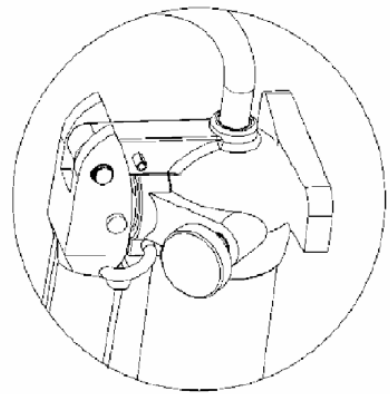

GENERAL DRAWING N° 3

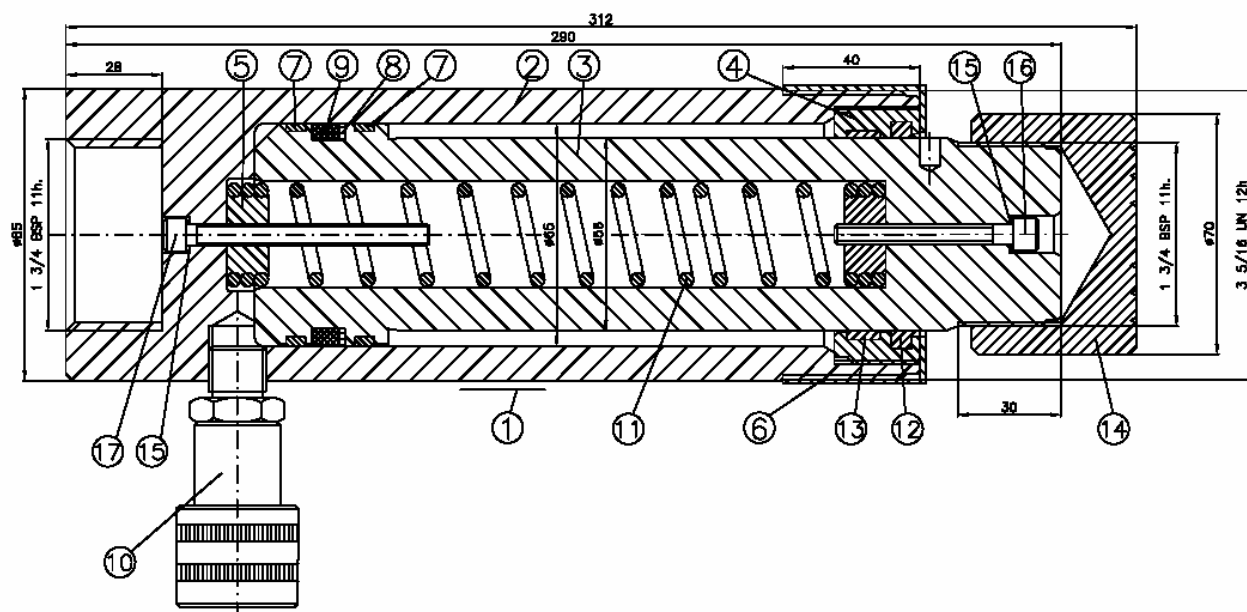

N	DENOMINACION	REFERENCIA JUNTAS	CODIGO	N Piezas	
1	ETIQUETA		30A0017	1	
2	CUERPO		52E0186	1	
3	EMBOLO		53H0011	1	
4	GUIA		55E0092	1	
5	TIRANTE MUELLE		24F0087	2	
6	PROTECTOR		12L0003	1	
*	7	ARO GUIA $\phi 65 \times \phi 60 \times 5.6$	GP6500650-C380	58F0112	2
*	8	SEGMENTO		57A0019	1
*	9	COLLARIN $\phi 65 \times \phi 55 \times 7.3$	B7 6055 P5008	12B0094	1
	10	ENCHUFE HEMBRA G.C		AZ3240	1
	11	MUELLE		13A0220	1
*	12	RASCADOR $\phi 56 \times \phi 56 \times 6$	WD2200560-WUAQ3	12H0071	1
*	13	ARO GUIA $\phi 56 \times \phi 61 \times 9.7$	GR6900560-C380	58F0135	1
	14	CABEZA DENTADA		56H0005	1
	15	ARANDELA COBRE		57B0001	2
	16	TORNILLO ALLEN M6x50		14A0171	1
	17	TORNILLO ALLEN M6x70		14A0125	1