

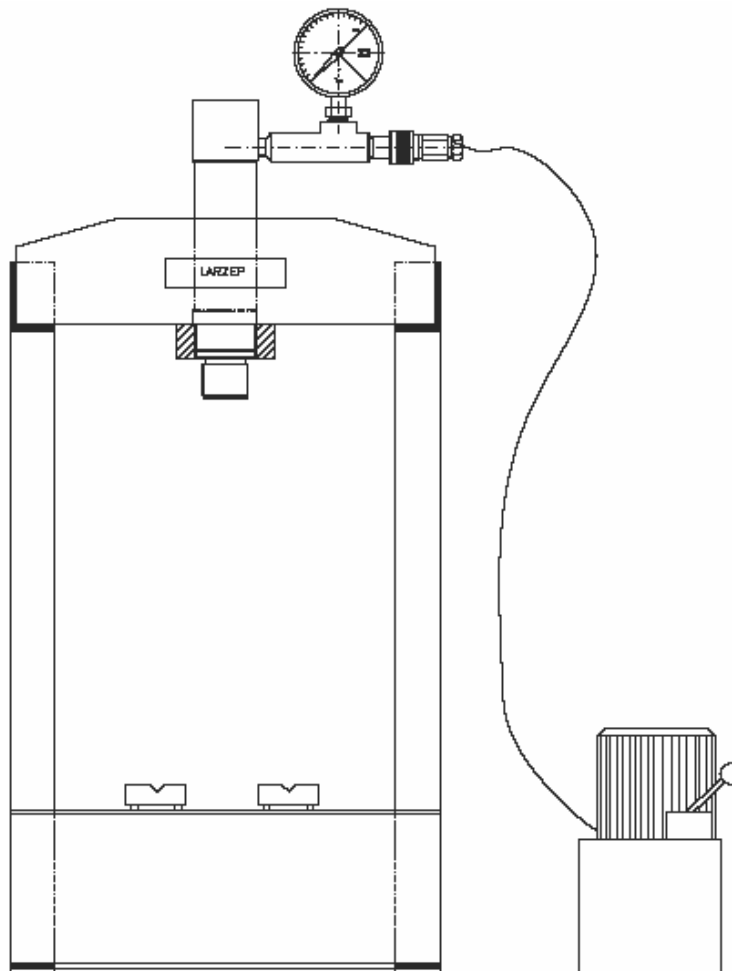

BENCH PRESS 20 ton WITH ELECTRIC PUMP

“ECE02013”



LARZEP, S.A.
Avda. Urtiaga, 6. 48269 MALLABIA (Vizcaya).Spain
P.O. Box, 27. 20600 Eibar (Guipúzcoa). Spain
Tel. (+34) 943-171200 - Fax. (+34) 943-174166
E-mail: comercial@larzep.com
www.larzep.com

LARZEP HYDRAULIC (UK) LTD
UNIT 1A PARK ROAD INDUSTRIAL ESTATE
CONSETT CO.DURHAM DH85PY. ENGLAND
Tel. (+44) - 1207-582266 - Fax. (+44)- 1207-583366
E-mail: enquire@larzep.co.uk
www.larzep.co.uk

INDEX

1. BEFORE USING THE EQUIPMENT 2
2. TECHNICAL FEATURES 2-3
3. ESSENTIAL SAFETY REQUIREMENTS 3
4. TRANSPORT AND INSTALLATION..... 4
5. MAINTENANCE AND DAMAGES 4-5
6. WARRANTY..... 5
7. DECLARATION OF CONFORMITY 6

ANNEX

- GENERAL DRAWING

1. BEFORE USING THE EQUIPMENT.

Before unpacking check for:

1. Oil leaks, signs of corrosion.
2. Damages in the hydraulic cylinder and the hydraulic line.
3. Damage sin the frames and accessories of the cylinder.
4. Damaged screws or connections.
5. Bad connection of the accessories.

If any anomaly it is detected, avoid the use of it and place it in a safe and far location until be repaired by an authorized service dealer.



Never use equipment suspected to be in poor conditions.

Familiarize the operators with the equipment before using it, and read and follow the instructions and recommendations included in the packaging. Any improper use, do not observed in this manual, and the omission of the same, may cause personal injuries and material damages which LARZEP, S.A. will not be responsible.



Do not loose the instruction manual.

Do not work with the equipment near of the flames, explosives, warm intense sources, or any other source which may produce fire, or which may produce damages in the equipment. The hydraulic equipment must not be exposed to temperatures greatest than 60°C, as on use as on storage.



If you are purchasing a cylinder or pump, for the use of it in the press, make sure that you are using a correct combination before assembling it. We recommended, asking for advice in this questions to our technicians.

When a place to the press is located, make sure that there is in a stable surface, is to say, that all base of the press, be supported. If any doubts exist about this question, it is recommended that distribute the weight in a bigger area, placing a steel shell behind the press's base.

Store the press when the piston is fully retracted. It is recommended protecting the cylinder with a plastic, or place the press in a clean area, for not damaging the components and for keeping the press correctly storage.

Never locate the press or store in a place where the children could access to it.

2. TECHNICAL FEATURES.

HYDRAULIC CYLINDER

MODEL	KC02013
• Push capacity (ton)	20 ton
• Maximum pressure (Kg/cm ²)	700 Kg/cm ²
• Stroke (mm.)	130 mm.
• Effective area (cm ²)	33.18 cm ²
• Oil capacity (cc)	431.37 cc.
• Approach speed (mm/sg)	31 mm/sg.
• Working advance speed (mm/sg)	5.8 mm/sg

HYDRAULIC MOTORPUMP. REF: YAM6224

MODEL	YAM6224
Tank capacity	4 Litres
Volume in low pressure. Approaching	3 Litres/min
Volume in high pressure. Working.	0.56 Litres min
Maximum pressure.	700 Kg/cm ²
Working pressure.	700 Kg/cm ²
Control valve	Electro-valve: hand 3 ways, 3 positions.
Motor	0.75 kW, 380V.50 Hz.3ph.

FRAME: MECHANICAL-WELDED

MODEL	ECE02013
• Working height (mm.)	330 mm
• Working width (mm.)	500 mm
• Weight (Kg.)	102 Kg.

DESCRIPTION MOTORPUMP YAM6224 (See drawing).

The motor pump has the following part:

- Metal tank (11) with oil level (7) and transport handles.
- Metal lid (9), support for the entire hydraulic circuit.
- Electric motor (8) with corresponding coupling (10).
- Hydraulic piston pump (5) with filter (6).
- Transportation plug and ventilation plug (plastic bag) (2).
- Pressure meter connection (1).
- Electrical cabinet or motor circuit breaker box.
- Manual distributing valve or electro valve with 3/8 NPT outputs (4)
- Internal safety valve adjusted to 700 Bar. (12).
- Adjustable external pressure regulating valve: 0-700 Bar (3).

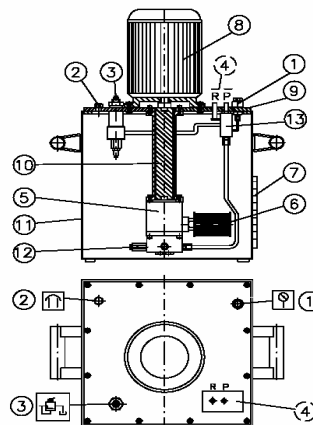

3. ESSENTIAL SAFETY REQUIREMENTS.

DANGEROUS AREA



Due to the *FUNCTIONAL REASONS* it is considered to be the space between the columns, the bed and the hydraulic cylinder piston.

Due to the *MATERIAL PRESSED* it is supposed to be surrounding area to the machine in case of metal parts being ejected during pressing.

The speed of the hydraulic cylinder during its extension is less than 30 mm/second. Therefore then machine should be considered by the application of ANNEX V of the Declaration of CE Conformity.

Operators standing in the dangerous area around the machine should protect their feet, faces and hands from metal pieces being ejected during pressing.



Feet protection



Face protection



Hands protection

Used materials and components are not dangerous for the health and safety of operators. The hand pump contains LARZEP hydraulic oil ISO: HV46.



HYDRAULIC OIL IS TOXIC IF IT ENTERS THE BLOODS STREAM. NEVER PLACE A FINGER OVER ANY ORIFICE OR LEAK, WHICH COULD BE PRESSURIZED, SUCH AS THE HYDRAULIC LINE, AS THIS COULD CAUSE OIL TO BE INJECTED INTO BLOOD STREAM.

SECURITY

- The cylinder advance in "manual" way, keeping pushed the button ▲ of the panel of push buttons, if we do not keep pushed the button, the cylinders stops. On this way, the cylinder returns while we keep pushed the button ▼, and the cylinder will stop if we do not keep pushed the button.
- In "automatic" way, the cylinder can advance without pushing any button, but to work in this way, we have to submit the cylinder to pressure, so nobody must be in the dangerous area between the cylinder and the treated material.
- The electrical cabinet is provided with a general selector (1-0) and with an emergency red stop pusher, easily identifiable and operable, locate din the panel of push button.
- The motor starts pushing the green button of the panel of button, and the motor stops when we push the red button.
- Only the general selector, located in the electric cabinet, allows the alimentation of the electric organs of the machine.
- The construction of machine has been calculated to bear without any breaking under conditions of foreseen utilization and for the whole life of the machine. The hydraulic components have been designed and calculated in compliance with the ANSI B30.1, and have been proved to 875Kg/cm² of pressing.
- The frame of the machine does not cause to be dangerous in that sense.
- The machine is provided with a thermal relay and a fuse to protect the remote control.
- The hydraulic pump is equipped with an internal security valve in the tank, out of operator's control and rated at 700 Kg./ cm². The hydraulic cylinder is also furnisher with a pressure relief valve, rated at 700 Kg./ cm², which could be rated by the operator from 0 to 700 Kg/cm².
- All the maintenance operations must be performed while the machine is stopped, thus avoiding this way any potentially dangerous situation. A poor maintenance program of the press does not increase the risk, but obviously will revert in a lower performance.
- The hydraulic pump is mounted out of the frame and access is very easy. To disassemble the pump unscrews the bolts in the tap cover. In order to disassemble the cylinder it is required first to disassemble the piping and the cylinder from the frame.
- Release the cables of the terminal to disconnect the current tap of electrical energy, previously disconnect the pin from the network.
- The press, the cylinder and the pump have their corresponding serial numbers marked on them. In addition to it, you can find a sticker label showing the commercial reference, capacity, working pressure, name and address of the manufacturer.

4. TRANSPORT AND INSTALLATION.

The machine is delivered properly packed in a wooden pallet. For its handling, it is recommended to use a forklift truck or a crane. In the last case, it is necessary to make the slings trespass the arc of the frame. When doing this operation, you should be cautious and prevent the flexible hoses and couplings from any damage.



The machine is stable enough to operate without fixing, but if it is placed in an area commonly operated by mobile machinery (cranes, lifting equipment...) it is strongly recommended to fix it to the desired place by drilling the supporting plates.

HYDRAULIC CONNECTION

Unscrew the rapid coupler site in the cylinder, and connect the hose, screwing the rapid coupler to the limit with the hand.

SUBSTITUTION OF THE TRANSPORT PLUG

Replace the plug of the transport located in the cover of the tank by the pressurized plug given with the press. (Plastic stock marked in the handle of the distributing valve).

INSTALLING THE GAUGE

1-Replace the threaded tap in the top of the cylinder by the gauge (supplied separately).

2-Tighten the gauge cone to the gauge adaptor seat by using a flan wrench size 22.

3-Hold the gauge screen by hand during threading process and after reaching a comfortable reading position set the gauge screen free so that it turns the last quarter solidarily with the thread.

4- The power pack is also provided with a gauge adaptor, with thread 3/8" BSP.

ELECTRIC CONNECTION

1- Connect the binding post to the network

2- See the voltage, it must be 380 V

3- Assure that the panel of push button is not pushed, and that the selector is in "manual" way (left.)

4- Put the general selector of the lateral of the electric cabinet in (1) position.

5- Push the green button. The motor starts.

6- Check that the motor goes in the sense labelled with an arrow in the motor. In opposite case, change the position of two cables between themselves in the terminal and try again. This operation must be done with the equipment disconnected.

7- Connect again the equipment and check the function of the emergency red button located in the panel of push button.

CHECKING THE RIGHT OPERATION OF ALL DEVICES AND MECHANISM

1. Select the working maximum pressure.

2. Put the general selector in position (1).

3. Push the green button to start the motor.

4. Check that the cylinder's piston advance.

5. Check that the cylinder's piston returns pushing by an internal spring. In both cases, to maintain the movement, it is necessary to keep pushed the button.

6. With no material in the press, repeat the movement of advance, reaching the end of the stroke of the cylinder. In this moment the pressure will go increasing, so the gauge will read the pressure. This pressure will go increasing until reach the maximum pressure of the installation, previously chosen. The cylinder maintains the reached pressure and the gauge the pressure reading check that there is not oil leaks.

7. To return the piston and depressurize the installation push the panel of button. The piston returns by the internal spring. The return could be slower in the end of the return stroke.

8. Put the material to be treated in the press.

9. Once the operation is finished, push the red button to stop the motor.

10. Put the general selector in (0) position,

START UP

Connect the machine as described in the previous point.

The maximum pressure that the hydraulic equipment develops is 700 Kg/cm².

The machine is provided with an external limiter valve rated on factory at 700 Kg/cm².

In the cover of the power pack is located the pressure regulation screw.

Release the lock nut and go tightening or releasing the screw, go checking with the gauge, and once that the wished pressure is reached; tighten the lock nut to avoid that the vibration may decontrol the system.

5. MAINTENANCE.

The hydraulic circuit of the press is closed, so in normal conditions no oil leakage should be coming up.

In case of oil leakage, after the proper repairing work, you should fill up the tank with hydraulic oil by LARZEP (Ref. AZ8901); the pump is equipped with an oil level indicator to control the need quantity of oil.

As far as a non-continuous use of the press is concerned (1 hour per day), oil replacement should be done once a year.



To empty the tank, you should remove the cover and take the oil out to another container. Please, bear in mind the existing rules for waste processing when handling the used oil.

Keep greasy and lubricated the pin bearings, the piston and in general all the parts that might be in friction.

USE ONLY LARZEP HYDRAULIC OIL

Other grades of oils or types of hydraulic fluid (such as brake fluid) may affect the performance of the equipment or cause the deterioration of the seals.



DO NOT ATTEMPT TO FILL THE PUMP WITH OIL WHILE IT IS CONNECTED TO A CYLINDER WHICH IS SUSTAINING A LOAD BECAUSE IT MAY OVERPRESSURIZE THE RESERVOIR WHEN THE PISTON RETRACS AND CAUSE DAMAGE OR INJURY

Always use the original LARZEP parts to prolong the service life of your hydraulic equipment. LARZEP S.A. or your authorized dealer can supply you with original parts for simple maintenance work.

PROBLEMS	POSSIBLE FAILLURES	SOLUTION
1. The piston does not advance.	- Prime fewer pumps.	1. Feed the pump keeping it started some minutes.
	- Dirty accumulated in the filter.	2. Extract and clean it.
	-No oil in the reservoir.	3. Check the level.
	- Cylinder pressure retainer damaged.	4. Replace the retainer.
	-Directional valve damaged.	5. Replace the valve.
	- Cylinders body damaged.	6. Repair the body of the cylinder.
	- Pneumatic problem.	7. Check the installation.
2. The cylinder does not reach pressures.	- Pressure relief valve unrated.	8. Rate the valve.
	- Cylinder pressure retainer damaged.	See Solution. 4.
	- Cylinders body damaged.	See Solution. 6.
3. The cylinder does not maintain pressure.	- Cylinder pressure retainer damaged.	See Solution. 4.
	- Directional valve damaged.	See Solution. 5.
4. The cylinder does not retract.	- Damaged return spring.	9. Replace the spring.
	- Directional valve damaged.	See Solution. 5.

The solutions marked in black must be carried out by specialized personnel, for it, go to an authorized distributor that sold you the equipment or to LARZEP, S.A., we have original spare part kits as well as the necessary personnel, do not doubt in contacting to us, we are to yours disposition.

Always use original spare parts LARZEP, you will extend the life utility of the equipment, in opposite case the company will not become person in charge of the possible failures, damages or losses that take place.

6. WARRANTY.

LARZEP, S.A. guarantees its products against all design and manufacturing defects for the durations of two years from the date of purchase. This guarantee does not include the ordinary wear of both metal and non-metal parts, abuse, using the equipment beyond its rated capacity and any wear or damage incurred as a result of using a hydraulic fluid which is not recommended by **LARZEP, S.A.**

Please note that if the equipment is disassembled or serviced by anyone other than an authorized service dealer or by **LARZEP, S.A.**, this guarantee is rendered null and void.

In the event of a warranty claim, return the equipment, to **LARZEP, S.A.** or the authorized dealer which sold you the hydraulic equipment, **LARZEP, S.A.** will repair or replace the faulty equipment, whichever is deemed most appropriate. **LARZEP, S.A.** shall not be held liable for any consequential damages or losses, which may occur as a result of faulty equipment

7. DECLARATION OF CONFORMITY.

DECLARACION DE CONFORMIDAD

LARZEP, S.A.
Dirección: Avda. Urtiaga, 6
48269 Mallabia ESPAÑA

Declaramos bajo nuestra exclusiva responsabilidad la conformidad de los productos a los que refiere esta declaración, con las disposiciones de la directiva: 89/392/CEE, 91/368/CEE, 93/44/CEE, 93/68/CEE, 98/37/CEE

E

DECLARATION DE CONFORMITE

Nous, LARZEP, S.A.
Adresse: Avda. Urtiaga, 6
48269 Mallabia SPAIN

Déclarons sous notre seule responsabilité que les produits auxquels se réfère cette déclaration sont conformes aux dispositions des Directives:

89/392/EEC, 91/368/EEC, 93/44/EEC, 93/68/EEC, 98/37/EEC

F

DECLARAÇÃO DE CONFORMIDADE

Nós, LARZEP, S.A.
Endereço: Avda. Urtiaga, 6
48269 Mallabia SPAIN

Declaramos, sob nossa única responsabilidade, que os seguintes produtos, incluídos nesta declaração estão em conformidade com o disposto na Directiva:

89/392/EEC, 91/368/EEC, 93/44/EEC, 93/68/EEC, 98/37/EEC

P

ÖVERENSSTEMMELSEERKLÆRING

Vi, LARZEP, S.A.
Adresse: Avda. Urtiaga, 6
48269 Mallabia SPAIN

Erklærer på eget ansvar, at følgende produkter som er omfattet af denne erklæringen, er i overensstemmelse med bestemmelserne i Direktiv:

89/392/EEC, 91/368/EEC, 93/44/EEC, 93/68/EEC, 98/37/EEC

DK

ERKLÆRINGOM OVERENSSTEMMELSE

Vi, LARZEP, S.A.
Adresse: Avda. Urtiaga, 6
48269 Mallabia SPAIN

Erklærer på eget ansvar, at følgende produkter som dækkes af denne erklæringen, er i overensstemmelse med bestemmelserne i Direktiv:

89/392/EEC, 91/368/EEC, 93/44/EEC, 93/68/EEC, 98/37/EEC

N

ÜBEREINSTIMMUNGSERKLÄRUNG

Wir, LARZEP, S.A.
Anschrift: Avda. Urtiaga, 6
48269 Mallabia SPAIN

Erklären auf eigene Verantwortung, daß folgende Produkte, auf die sich diese Erklärung bezieht, mit den Bedingungen der Direktiven 89/392/EEC, 91/368/EEC, 93/44/EEC, 93/68/EEC, 98/37/EEC übereinstimmen.

D

Tipo, Type, Typ, Tyyppi.

SM / SH / SP / SMP / SX / SMX / ST / STX / SL / SMA / SHA / SSR / T / TE / TD / D / DH /
DDR / Z / ZR / W / X / YA / YG / YZ / HM / HE / HG / HZ / HS / WI / CK / CC / CN / FU / FV
/ FZ / FA / CY / AA / AU / CT / C / KC

A / AB / AC / BL / B / AF / F / HN / DLG / DL / DP / VA / VB / VC / VZ / EC / EE / EG / EM /
EZ / CA / CS

Mallabia, ESPAÑA 2005 / 04 / 27

Lugar y fecha, place and date, lieu et date, plats och datum, paikka ja päivämäärä, udstedelsessted og-dato, ort und datum, plaats en datum, local e data, luogo e data.

DECLARATION OF CONFORMITY

We, LARZEP, S.A.
Address: Avda. Urtiaga, 6
48269 Mallabia SPAIN

Declare under our sole responsibility that the following products to which this declaration relates conform with the provisions of Directives:

89/392/EEC, 91/368/EEC, 93/44/EEC, 93/68/EEC, 98/37/EEC

GB

DICHIARAZIONE DI CONFORMITÀ

Noi, LARZEP, S.A.
Indirizzo: Avda. Urtiaga, 6
48269 Mallabia SPAIN

Dichiariamo sotto la nostra esclusiva responsabilità che i prodotti ai quali questa dichiarazione si riferisce sono conformi quanto previsto dalle Direttive:

89/392/EEC, 91/368/EEC, 93/44/EEC, 93/68/EEC, 98/37/EEC

I

VAATIMUSTEMUKAISUUSVAKUUTUS.

Me, LARZEP, S.A.
Osoite: Avda. Urtiaga, 6
48269 Mallabia SPAIN

Vakuutamme yksinomaan omalla vastuullamme, että seuraavat tuotteet, joihin tämä vakuutus liittyy, ovat seuraavien Direktiivien vaatimusten mukaisia:

89/392/EEC, 91/368/EEC, 93/44/EEC, 93/68/EEC, 98/37/EEC

FIN

VERKLARINGVAN OVEREENKOMST.

Wij, LARZEP, S.A.
Adres: Avda. Urtiaga, 6
48269 Mallabia SPAIN

Verklaren geheel onder eigen verantwoordelijkheid dat de volgende producten, waarop deze verklaring heeft in overeenstemming zijn met de bepalingen van Richtlijn:

89/392/EEC, 91/368/EEC, 93/44/EEC, 93/68/EEC, 98/37/EEC

NL

FÖRSÄKRAN OM ÖVERESSTÄMMELSE

Vi, LARZEP, S.A.
Adresse: Avda. Urtiaga, 6
48269 Mallabia SPAIN

Försäkrar under eget ansvar att följande produkter som omfattas av denna försäkran är i överensstämmelse med villkoren i Direktiv:

89/392/EEC, 91/368/EEC, 93/44/EEC, 93/68/EEC, 98/37/EEC

S

LARZEP, S.A.

Nombre y firma, name and signature, nom et signature, namn och underskrift, nimi ja nimikirjoitus, navn og underskrift, name und underskrift, naam en handtekening, nome e assinatura, nome e firma.

PRENSA HIDRAULICA DE SOBREMESA

Ref.Comercial: ECE02013

DATOS DE LA PRENSA:

CAPACIDAD 20 Tm
LUZ ENTRE COLUMNAS 500 mm
ALTURA MINIMA TRABAJO 220 mm
ALTURA MAXIMA TRABAJO 350 mm

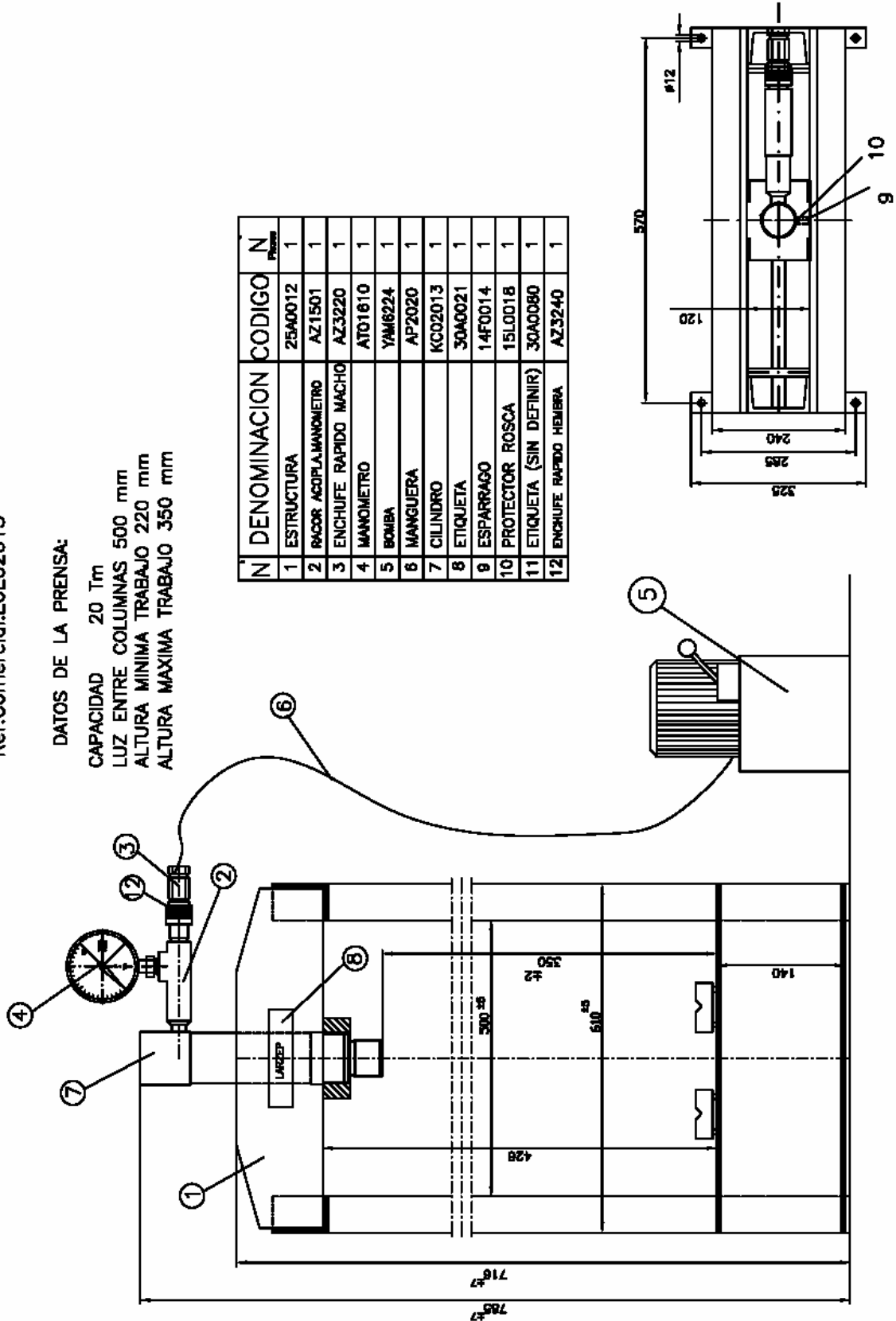

N	DENOMINACION	CODIGO	N
1	ESTRUCTURA	25A0012	1
2	RACOR ACOPLA.MANOMETRO	AZ1501	1
3	ENCHUFE RAPIDO MACHO	AZ3220	1
4	MANOMETRO	AT01610	1
5	BOMBA	YAM6224	1
6	MANGUERA	AP2020	1
7	CILINDRO	KC02013	1
8	ETIQUETA	30A0021	1
9	ESPARRAGO	14F0014	1
10	PROTECTOR ROSCA	15L0018	1
11	ETIQUETA (SIN DEFINIR)	30A0080	1
12	ENCHUFE RAPIDO HEMBRA	AZ3240	1

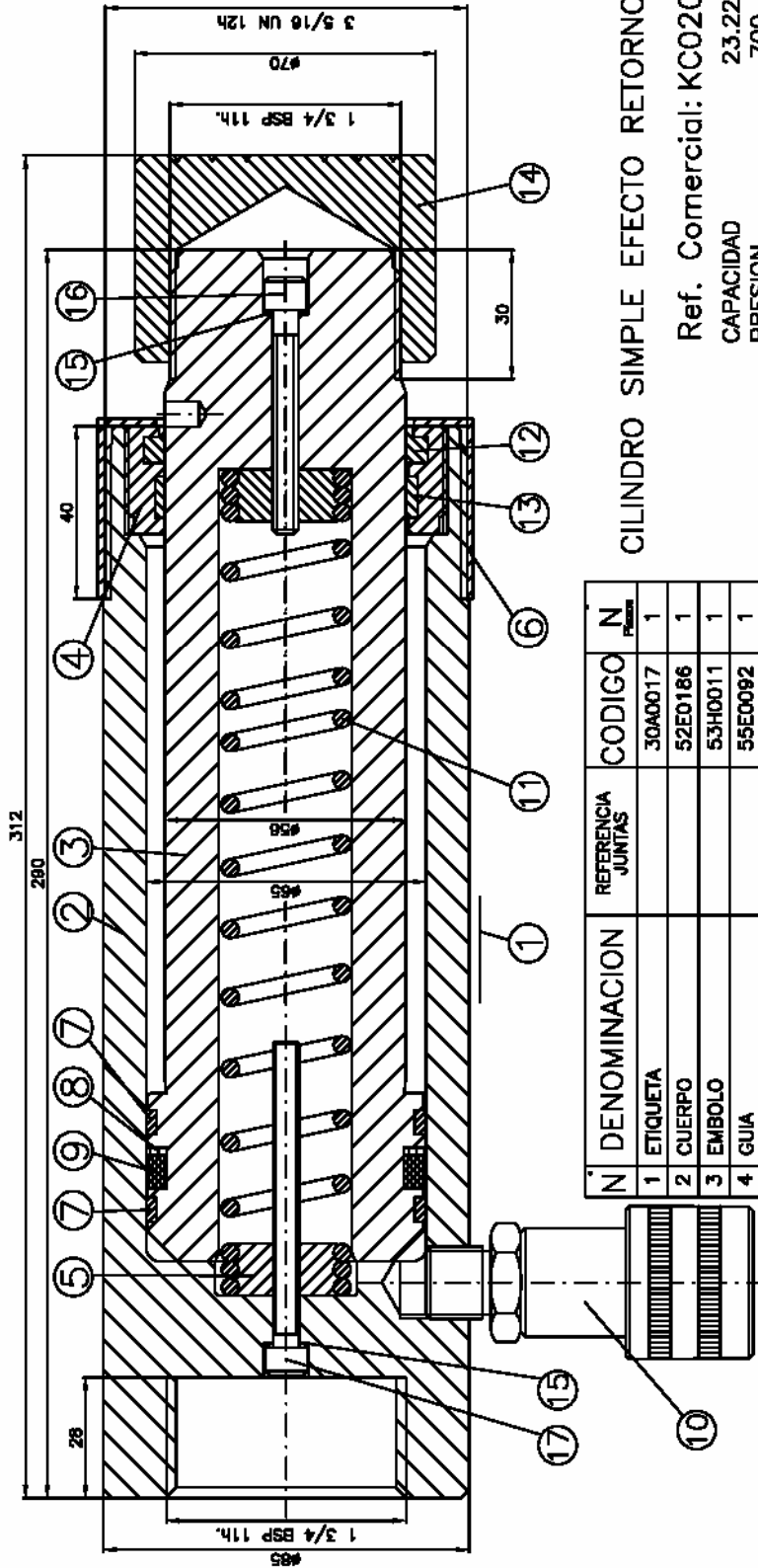

CILINDRO SIMPLE EFECTO RETORNO POR MUELLE

Ref. Comercial: KC02013
 CAPACIDAD 23.22 Tm (227.79 kN)
 PRESION 700 Kg/Cm²
 ALTURA CERRADO 290 mm
 CARRERA 130 mm
 AREA 33.18 Cm²
 VOLUMEN ACEITE 431.37 Cm³

N	DENOMINACION	REFERENCIA JUNTAS	CODIGO	N
1	ETIQUETA		30A0017	1
2	CUERPO		52E0186	1
3	EMBOLO		53H0011	1
4	GUIA		55E0092	1
5	TIRANTE MUELLE		24F0087	2
6	PROTECTOR		12L0003	1
7	ARO GUIA #55x#60x5.6	CP8500650-C380	58F0112	2
8	SEGMENTO		57A0019	1
9	COLLARIN #65x#55x7.3	B7 6055 P5008	12B0094	1
10	ENCHUFE HEMBRA G.C		AZ3240	1
11	MUELLE		13A0220	1
12	RASCADOR #56x#66x6	WD2200580-WUA03	12H0071	1
13	ARO GUIA #56x#61x8.7	OR8600650-C380	58F0135	1
14	CABEZA DENTADA		56H0005	1
15	ARANDELA COBRE		57B0001	2
16	TORNILLO ALLEN M6x50		14A0171	1
17	TORNILLO ALLEN M6x70		14A0125	1